

SEMAK

SEMAK GAS FIRED ROTISSERIE – MODEL 36G

INSTALLATION, OPERATION AND WARRANTY BOOKLET



SEMAK AUSTRALIA: FACTORY 18, 87-91 HALLAM SOUTH ROAD, HALLAM VIC 3803

PH +61 3 9796 4583

FAX +61 3 9796 4586

WEB WWW.SEMAK.COM.AU

Table of Contents

Introduction.....	3
Installation	4
Installation/Certificate Details.....	4
Installation - Electric Rotisseries.....	5
Installation Complete Test.....	5
Installation Minimum Clearance	6
AGA Gas Regulations	6
Installation Procedure	7
Data Plate & Model	8
Exhaust Systems	8
To Convert to LPG.....	8
Installation Check Procedure.....	9
Hourly Gas Consumption and Injector Size:	9
Wiring Diagram:.....	10
Parts of the Rotisserie	11
Pilot and Sensor Inspection Point.....	11
Location of Pilot Test Point.....	11
Adjusting the Valve.....	11
Features of the Motor BoxSafety Instructions cont:	12
Safety Instructions cont:.....	13
Safety Instructions cont:.....	14
General Instructions:	15
Remember these Points	15
If the Rotisserie Fails to Operate:	15
Loading	15
Operating Instructions.....	16
Cooking.....	16
Unloading	16
Cleaning	17
Spit Sleeve Inserts	17
Glass Care	17
Points to Remember.....	18
Service and Repair	18
Service and Repair Procedure	18
Warranty.....	19
FAQ—Troubleshooting.....	20
1. Gas Related Problems	20
2. Electrical Problems.....	20
3. Mechanical Problems.....	20
Repair Request Form	21
Hand Over Checklist	22
Store Copy	22
Hand Over Checklist	23
Head Office Copy	23
Hand Over Checklist	24
Semak Copy	24
Warranty Registration	25

Introduction

At Semak we have only one mission, to *manufacture excellence*.

By achieving this we are able to meet all of our customer's expectations.

Semak products are recognized for their:

- Quality
- Durability
- Longevity
- Performance
- Simplicity

Semak rotisseries have been serving Australians for nearly 60 years and are the market leader. They also proudly carry the Australian Made Logo.



They are a specialist oven professing to do only one thing and do it better than any other cooking method.

Semak rotisseries cook chickens better than anything else. The result is second to none making rotisserie chicken the most sought after chicken in the fast food market.

The difference is in the taste achieved by the slow roasting and self-basting of rotating chickens. Nothing else!

Semak Rotisseries produce an unadulterated, healthier product:

- Free of air and waterborne contaminants common in other ovens
- Free of additives such as marinades and seasoning
- Lower in fat and cholesterol

Semak Rotisseries are

- Easy to Clean
- Simple to operate
- Environmentally Responsible
- Serviceable
- Proven profit makers

Installation

Semak Rotisseries **MUST** be installed by a qualified Electrician (electric machines) or Plumber / Gas Fitter (Gas Machines).

The Rotisserie should be installed by an authorised person in accordance with the Manufacturer's instructions, local gas fittings regulations, Municipal Buildings Codes, Electrical Wiring Regulations, The Australian Gas Association Code for Gas Burning Appliances and Equipment AS5601 and any other relevant statutory regulations.

Failure to properly meet this installation requirement will **VOID** the warranty on the machine. This requirement is to protect the Interests of the consumer and reduce the possibility of property damage or loss.

In the event of breakdown, Semak will require proof that the installation of the machine was completed by a registered Electrician or Gas Fitter.

The proof required would be a completed certificate of compliance registered with the relevant inspections office.

Installation/Certificate Details

To facilitate prompt service record the details of the certificate of compliance below

Certificate Title

Certificate Number

Date Installed

Name of Installer

Licence Number

Company Name

Company Phone

Installation - Electric Rotisseries

The installer must be able to provide a Certificate of Compliance on completion of the installation. Supply of the licence is the responsibility of the installer. While it is the responsibility of the installer to provide the Certificate of Compliance, it is the responsibility of the purchaser to ensure one is received and warranty claims will not be recognized until a copy of the Certificate or the Certificate Number is received and cross referenced.

Failure to supply a Certificate of Compliance is an offence and should be reported immediately to the Office of the Chief Electrical Inspector or the relevant Regulatory Office.

Installation Complete Test

The rotisserie **MUST** be tested following installation to ensure its correct operation. Please complete the details below as proof that the rotisserie is operating correctly.

This Rotisserie Model No 36G Serial No:.....

HAS BEEN TESTED READY FOR OPERATION ON:

NATURAL GAS	KPA	0.75	[]
LPG	KPA	2.6	[]
LPG Inlet Pressure	KPA	2.75	[]
NATURAL GAS Inlet Pressure	KPA	1.1	[]

Tested OK []

SIGNED
(TEST TECHNICIAN/ PLUMBER & GAS FITTER)

NAME:
(PRINT)

Company:
(PRINT)

Licence Number:
(PRINT)

DATE

Installation Minimum Clearance

Increase minimums to 600 mm if butted up close to glass windows, mirrors, display equipment etc...

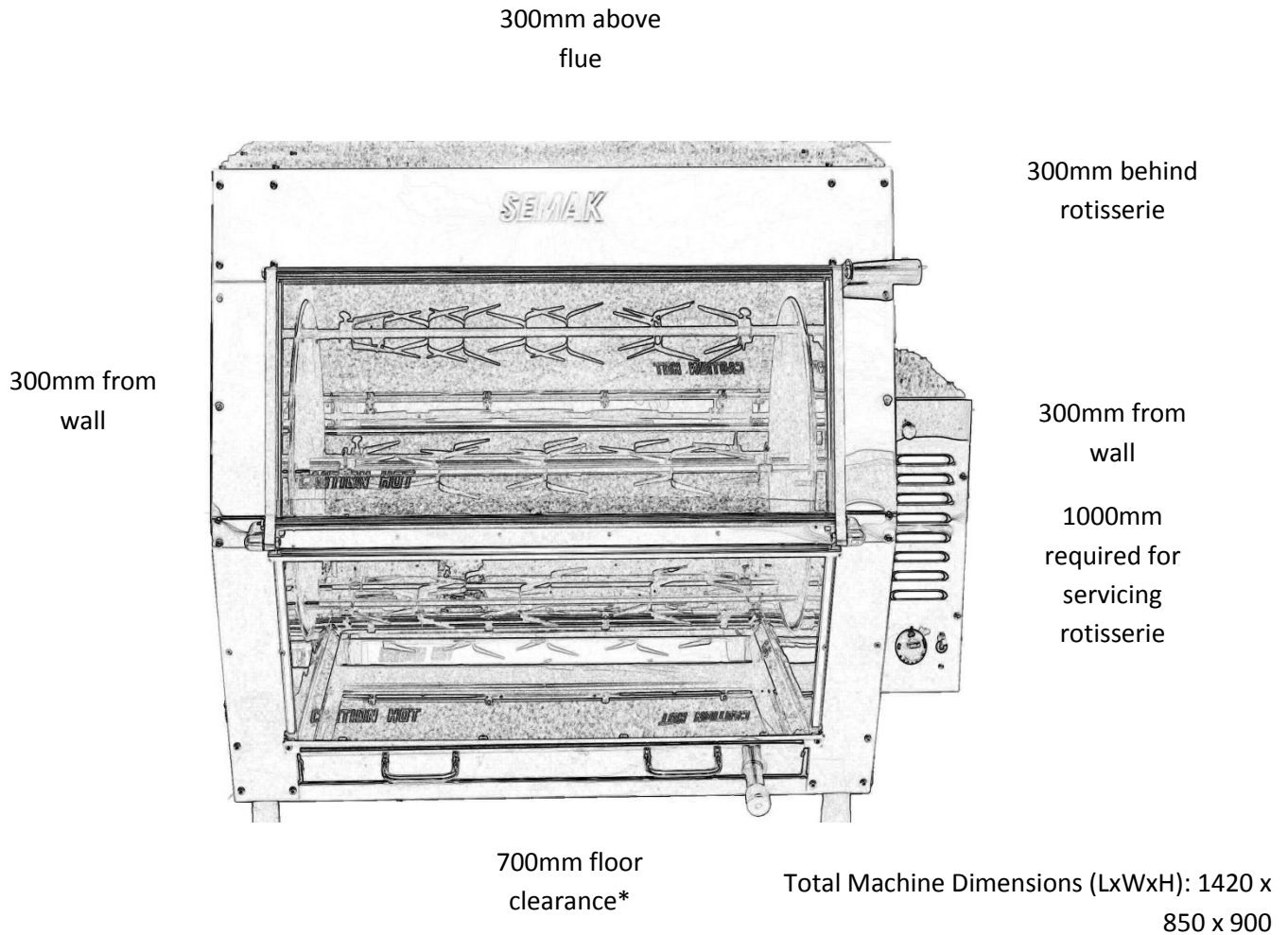

*Machine pictured may differ from the model purchased

AGA Gas Regulations

1. Australian standard 1668 Parts 1 & 2 for kitchen exhaust needs
2. Relevant Authority (Building & Health)
3. Exhaust Regulations—AS 1668 part 1
4. Gas Fitting Regulations 153, 155 & 156
5. AS 5601

Installation Procedure

1. Check the location of power.
2. Check the location of necessary connections.
3. Position the rotisserie ensuring to note the minimum clearances required around the machine (see page 6)
4. Allow sufficient room in front of the machine to minimize collisions and to remove the drip tray (500 mm). The machine gets very hot and if touched may cause severe burns.
5. Plug in to an existing 10 amp plug.
6. The rotisserie is a 240 volt appliance with rear gas burner and motor. The rotisserie runs on LPG or NG. Check rating plate.
7. Gas supply piping to the appliance should be designed in accordance with the Gas Association Installation Code for Pipe Sizing and should be connected to the appliance in accordance with Gas Fitting Regulation No 116. The inlet gas connection is $\frac{3}{4}$ " BSP .
8. If the rotisserie is positioned on a mobile trolley then:
 - A $\frac{3}{4}$ " flexible gas hose and quick release fitting should be used. A G A Approval No. 1884
 - A restraining chain/wire shall be attached to the wall and the cooker within 50mm of the flexible hose attachment points and shall restrain the appliance movement to 80% of the hose length.
 - The inlet gas $\frac{3}{4}$ " BSP fitting is located on the LEFT HAND when viewed from the rear side of the rotisserie
9. Should the Rotisserie be installed within the building for use on LPG Gas , the bottle must not exceed 1 x 9 kg, and if the bottle is fitted with a relief valve it must be vented to atmosphere.
10. If the appliance is connected to external LPG supply, then the gas pipeline to the appliance should be designed in accordance with the Australian LPG installation code for the pipe sizing and should be connected to the appliance via a flexible tubing and bayonet cock supply in accordance with LPG regulations. Gas supply and bayonet cock to be properly secured in a rigid position with the outlet of the bayonet cock facing downwards. It is recommended that a locking type cock be fitted prior to the fitting of the bayonet cock.
11. The appliance shall be installed with at least 300 mm clearance from the combustible material except that at least 50 mm clearance shall be maintained between the Flue Box or Draught Diverter and combustible material.
12. Where an appliance is mounted on a combustible surface. In all other cases the appliance should be mounted on a fire-resistant material at least equal in insulating properties to 9.5 mm thick millboard. All such materials shall be made impervious to cooking fats and shall extend at least 50 mm beyond the edges of the appliance.
13. There shall be a vertical distance not less than 1200 mm clearance between any open burner, griddle, barbeque etc. and any combustible material.

Data Plate & Model

The identification plate is located on the motor box panel.

Exhaust Systems

Commercial cooking equipment used in processes which produce smoke or grease laden vapours shall only be installed in locations which are equipped with an exhaust system comprising of a hood where applicable, duct system and facilities as specified in AS 1668 pt. 1 and as detailed hereunder.

1. Exhaust hoods shall be of design and construction such that they can be readily and efficiently cleaned and they shall be manufactured of material impervious to fat, grease and vapour. Inside faces shall be smooth and free of obstructions and all joints shall be grease tight. Their location shall be such that they effectively ventilate the cooking equipment.
2. Unless otherwise approved, hoods shall extend not less than 150 mm beyond the perimeter of the equipment to be ventilated.
3. Exhaust ducts shall be adequately sized and shall conform to all fire authority and health department requirements. Ducts shall not be connected to other ventilation or exhaust systems.
4. Suitable grease traps shall be provided to prevent entering the duct system. They shall be so located that they will not present a fire hazard and are readily accessible for regular cleaning. The height of the lowest edge of grease filters located above the cooking surface shall be not less than:
5. Hoods and ducts shall have a minimum clearance of 450 mm to combustible material unless adequately protected. The distance between the floor and the lower edge of the canopy shall not be less than 2m.
6. Hoods shall be located over all griddles, barbeques or similar appliance installed indoors.

To Convert to LPG

1. Install LPG injector into Main Burner
2. Install LPG injector into pilot assembly.
3. Change spring in valve installing it to the High side only
4. Change spring in pilot regulator
5. Place stickers provided on the valve
6. Adjust pressures as per noted High and Low
7. Check correct pressure at pilot test point and adjust if necessary

Installation Check Procedure

1. Firstly, ensure gas supply to valve unit and power supply is "ON"

· **"Never try to use ignition unless gas valve is open otherwise damage may result"**

· **Pilot for main burner is located beneath the burner.**

2. To ignite the main burner with ALL switches in the OFF position,

Turn the motor switch to the ON position.

Turn the burner switch to the ON position.

The pilot will light the burner once the pilot is established.

3. If the pilot does not light

Turn the burner switch to the OFF position

Turn the burner switch to the ON position

The pilot will light the burner once the pilot is established.

NOTE: You may need to repeat this a number of times to bleed air from the pipes e.g. a new machine being installed or gas being reconnected following a service

4. Once the burner is lit turn the burner switch to HIGH or LOW

Hourly Gas Consumption and Injector Size:

N.G. (HIGH)	N.G. (LOW)	N.G.	L.P.G. (HIGH)	L.P.G. (LOW)	L.P.G
MJ	MJ	MM	MJ	MJ	MM
95	75	4.6	75	60	2.5

Pilot Gas Consumption:

N.G	L.P.G
KPA	KPA
0.85	0.55

Pilot Pressure at Test Point

N.G	L.P.G
KPA	KPA
0.80	2.60

Inlet Gas Pressure Test Point:

N.G	L.P.G
KPA	KPA
1.10	2.75

Outlet Pressure at Test Point

MODEL 36G	N.G.	L.P.G.
	KPA	KPA
HIGH	0.75	2.60
LOW	0.55	1.55

Power Requirements: AC Only

WATTS	VOLTS	P.H	CYL
170W	220-240V	1	50HZ

Wiring Diagram:

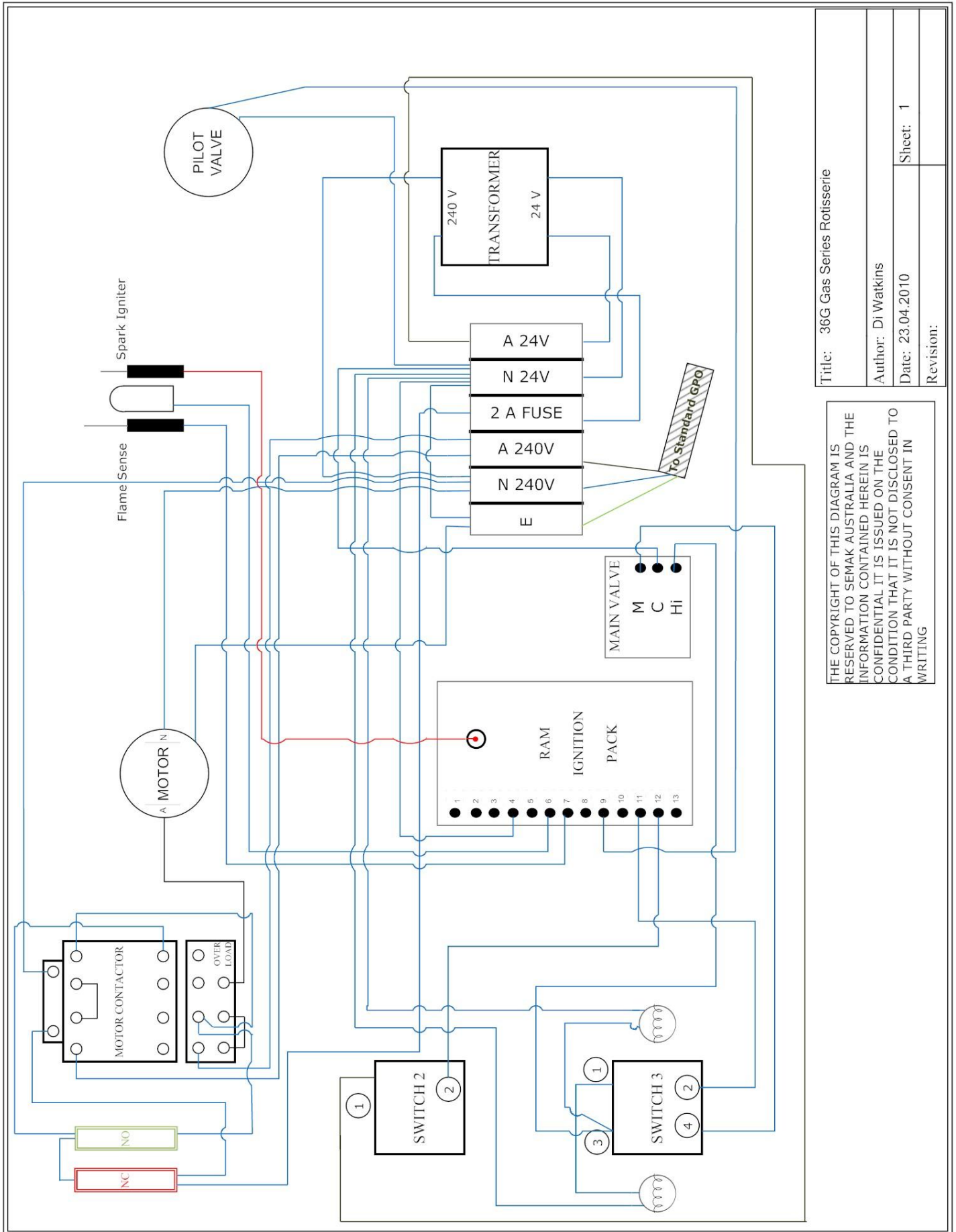

Title: 36G Gas Series Rotisserie
Author: Di Watkins
Date: 23.04.2010
Sheet: 1
Revision:

THE COPYRIGHT OF THIS DIAGRAM IS RESERVED TO SEMAK AUSTRALIA AND THE INFORMATION CONTAINED HEREIN IS CONFIDENTIAL IT IS ISSUED ON THE CONDITION THAT IT IS NOT DISCLOSED TO A THIRD PARTY WITHOUT CONSENT IN WRITING

Parts of the Rotisserie

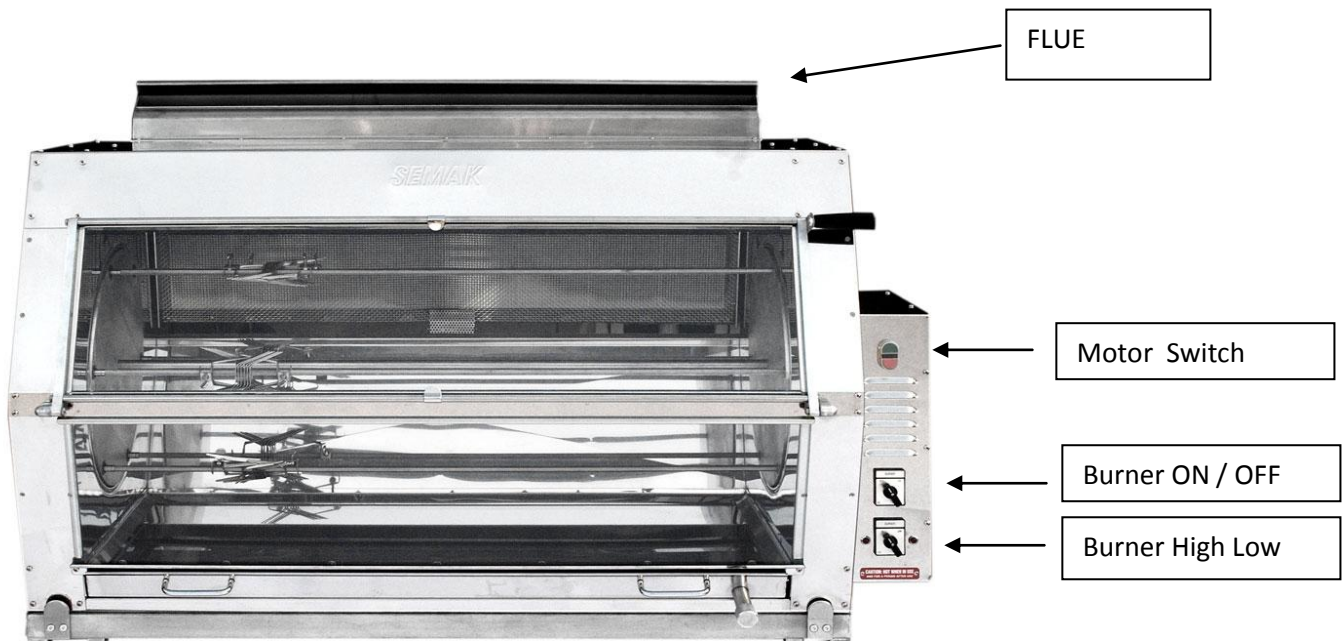

Pilot and Sensor Inspection Point

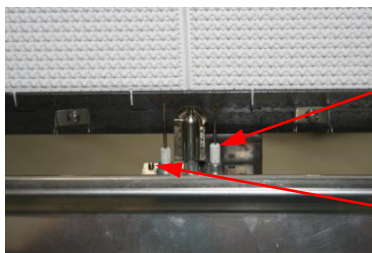

Sparker

Located inside the machine at the bottom of the burner in the centre

Sensor

Location of Pilot Test Point



Located with the solenoid in the rear wiring channel behind the machine

Adjusting the Valve



Located on the valve. Use a screw driver to adjust the HI LOW settings according to gas type and specifications on page 9

Features of the Motor Box

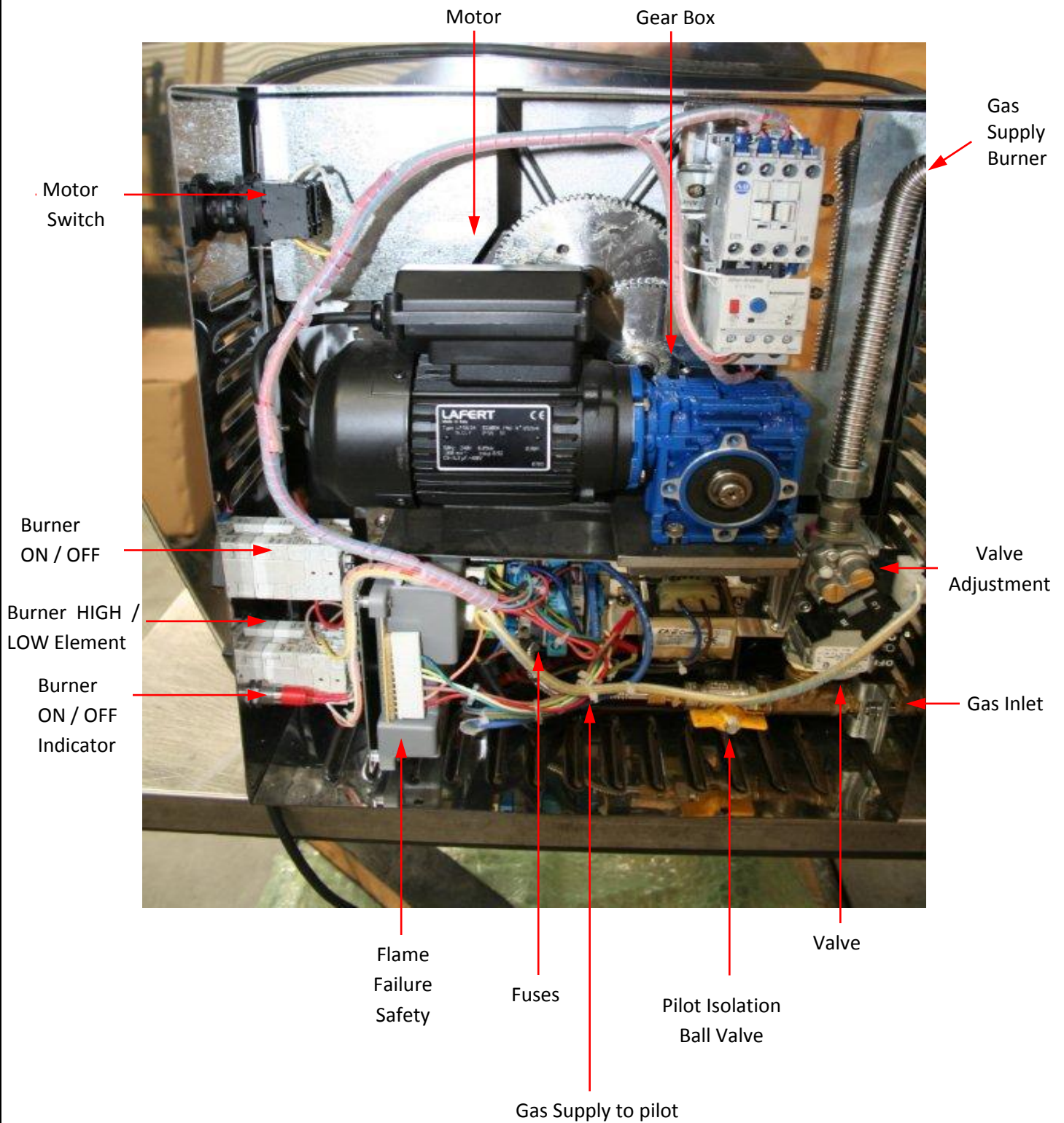

Safety Instructions cont:

WARNING: PLEASE ENSURE THAT ALL SAFETY INSTRUCTIONS ARE UNDERSTOOD BY ALL PERSONS WHO USE THIS APPLIANCE

Arabic

تحذير: تأكد من فهم كل من يستعمل الجهاز
لكافة احتياطات الأمان وتعليمات التشغيل.

Cambodian

ការព្រមានច្រប៉: សូមត្រួតពិនិត្យបានច្បាស់ថាការប្រុងប្រយ័ត្នផ្នែក
និរតិយ និងរបៀបប្រើទាំងអស់ បានត្រូវតាមច្រប៉ច្បាស់លាស់
ល្អ ទេរាដល់អ្នកដែលប្រើត្រឡប់ប្រដាប់នេះហើយ ។

Chinese

警告: 必需確保任何使用這器具的人士,
已明瞭一切安全預防措施及操作指示。

Croatian

Upozorenje: Budite sigurni da svi
koji rade na aparatima znaju o
mjerama opreza i funkciji ovih
aparata.

French

Attention: Veuillez vous assurer que
toutes les personnes utilisant
l'appareil comprennent tous les
conseils d'utilisation et précautions
de sécurité.

German

Warnung: Versichern Sie sich, daß
alle Sicherheitsvorkehrungen und
Bedienungsanleitungen von allen
Benutzern des Gerätes verstanden
worden sind.

Greek

Προειδοποίηση: Βεβαιωθείτε ότι όλα τα
προφυλακτικά μέτρα ασφαλείας και οι οδηγίες
λειτουργίας κατανοούνται από όλα τα άτομα
που χρησιμοποιούν τη συσκευή.

Italian

Attenzione: assicuratevi che tutti
coloro che adoperano i macchinari
conoscano le misure di sicurezza e le
istruzioni relative al funzionamento.

Macedonian

Предупредување: Осигурајте сите оние кои
користат апарати ги разбираат мерките за
безбедност и упатства за работа.

Malay

Amaran: Pastikan bahawa semua
langkah keselamatan dan
keterangan operasi telah difahami
oleh semua pengguna alat ini.

Polish

Ostrzeżenie: upewnij się, że wszystkie środki
ostrożności i instrukcje obsługi są rozumiane przez
wszystkich używających tego urządzenia.

Portugese

Atenção: Assegure-se de que todas as
medidas de segurança e instruções de
funcionamento são compreendidas por
todos aqueles que usam este aparelho.

Russian

Предупреждение: позаботьтесь о том, чтобы все
меры безопасности и инструкции по эксплуатации
были поняты всеми, кто пользуется этим
устройством.

Serbian

Упозорење: Водите рачуна да сви који
употребљавају овај уређај знају мере
предострожности и упутства за руковање.

Spanish

Advertencia: Haga que las
precauciones e instrucciones para el
uso de este aparato sean entendidas
por todos los que lo usan.

Tagalog

Babala: Siguruhing ang lahat nu
mga pangkaligtasang pag-iingat at
mga tagubilin hinggil sa
pagpapaandar ay naiintindihan ng
lahat ng gumagamit ng
kasangkapan.

Turkish

Uyarı: Tüm güvenlik önlemlerinin ve aygıtı
çalıştırma talimatlarının aygıtı kullanan herkes
tarafından anlaşılması sağlanmalıdır.

Vietnamese

Lưu ý: Chắc chắn rằng những người sử dụng
máy đều đã hiểu rõ tất cả các chỉ dẫn về cách
vận hành máy và các dự phòng an toàn.

Safety Instructions cont:

1. Read carefully, all the instructions provided before using the appliance and ensure that other operators also read and are made to understand all safety and operating instructions. Save these instructions for future reference.
2. Do not use the appliance for other than its intended use
3. Never leave the appliance unattended when in use.
4. The appliance should not be used by children or infirm persons and close supervision is necessary when used near children.
5. Always switch off at the power outlet before removing the plug. Remove by holding the plug- do not pull the cord.
6. When the appliance is not in use, or prior to cleaning it: always switch off the power and remove the plug.
7. To avoid the risk of electric shock, do not immerse cord, plug or motor part of the appliance in water or any other liquid.
8. Do not use near a stove or heat source and do not let the cord come in contact with any hot surface or water.
9. Do not use the appliance with an extension cord unless the cord has been checked and tested by a qualified technician or if it is an extension cord that has been manufactured by a reliable electrical goods manufacturer and has not been altered in any way.
10. Do not operate any appliance with a damaged cord or plug, or after the appliance malfunctions or has been dropped or damaged in any way. Return to Semak or its Authorised Service Agent for repair.
11. DO NOT SPRAY AEROSOLS IN THE VICINITY OF THIS APPLIANCE WHILE IT IS IN OPERATION
12. DO NOT STORE FLAMMABLE MATERIALS IN OR NEAR THE APPLIANCE

ENSURE THAT THE ABOVE SAFETY INSTRUCTIONS ARE UNDERSTOOD BY ALL PERSONS WHO USE THE APPLIANCE.

General Instructions:

1. NEVER hose the interior or exterior of the rotisserie for cleaning purposes as damage may result. The rotisserie does not have a fully enclosed cabinet and water can enter the electrics of the machine if hosed.
2. NEVER run the rotisserie unbalanced except for loading and unloading purposes. The motor and gears will last indefinitely if this principle is adhered to. Run the machine with a minimum of three evenly loaded spits
3. NEVER operate on high (Maximum) for full cooking time on a partly loaded machine. Remember that the rotisserie is designed to run on full heat for full time on a fully loaded machine. On a slightly loaded machine the heat is transmitted to the cabinet and not the chickens and distortion could result.
4. NEVER load or unload the machine whilst the machine is operating.
5. NEVER place metal foils such as aluminium foil etc in the drip tray or anywhere else in the rotisserie.
6. Should your rotisserie fail electrically check your fuses and main switches before calling for service.
7. Ensure that the spits and skewers are cleaned thoroughly before using for the first time. Scrub them in hot water with detergent and wipe them down with a food grade sanitizer.

Remember these Points

1. Ensure that the wall plug is securely connected.
2. Ensure all gas fittings are properly connected
3. Do not operate on HIGH heat unless machine is fully loaded.
4. Balance loads and do not operate with only one spit.
5. Handle glass doors with extreme care
6. Spit sleeve inserts should be cleaned daily.
7. When cleaning do not hose machine.
8. Switch off all controls and power supply when not in use

If the Rotisserie Fails to Operate:

The burner is fitted with a flame failure device. If the burner will not light gas will be cut to the burner if the burner fails to light repeat the installation check procedure (page 9.)If still unsuccessful call Semak on 03 9796 4583 or contact a gas fitter to assess the machine.

Loading

1. Spit up chickens, place an end skewer (with thumb screw) at the ball end of spit tighten thumb screws then place chicken on the spit by spearing the chicken from bottom end to neck with a middle skewer repeat until spit is full leaving 2.5 cm clearance at each end of the spit. Repeat until all spits are full.
2. Insert spits in the rotisserie. Use the Motor ON/OFF switch to rotate the disc assembly of the machine to the front of the machine to make loading easy. Insert the ball end of the spit into the spring loaded spit sleeve assembly located in the left disc and push the other end of the spit into the drive dog in the opposite corresponding disc position. Ensure that the end of the spit is properly engaged in the drive dog. If the spit is not properly engaged in the drive dog it will wear and place undue stress on the gears and motor. Turn the disc to the next position and repeat until the machine is fully loaded. Apply seasoning prior to loading Do not operate the machine with only one spit. Always balance loads.

Operating Instructions

1. Wash all surfaces and parts in contact with food thoroughly before using the machine.
2. Turn burner on by using the Burner ON/OFF switch. Sparking will occur and the pilot will light.
3. If the pilot does not light turn the burner switch OFF
4. Then turn the burner switch ON to establish the pilot.
5. Repeat this as many times as is required to establish the pilot remembering that air may need to be bled from the pipes following installation for the first time or re-connection of gas following a service.
6. When the burner is lit turn the burner switch to the HIGH or LOW position.

Cooking

7. The machine will take from 90-120 minutes to cook a full load of chickens depending on chicken size and core temperature on entry to the rotisserie. Maintain the temperature at 400°C and do not use water in the drip tray for the quickest cook time. Turn oven down if required to avoid burning.
8. There are many variables that affect the cooking time and experience is the best guide for the best cooking results. Typical indications of properly cooked birds are no free blood visible, legs removable with ease and bone marrow dark grey. The chicken is not cooked unless it has reached a core temperature of 75°C. Many operators however, prefer chickens to have reached a core temperature of 80°C—90°C.
9. It is important that each batch is checked in this regard. It is a requirement of a HACCP based food safety program.

Size	High (400°C)
10	90 mins approx
11	90 mins approx
12	120 mins approx
13	120 mins approx
14	120 mins approx
15	120 mins approx

Note: Bird core temperature, use of stuffing's, marinades and variation in chicken sizes will influence cook times and the consistency of results

Unloading

10. When the birds are cooked turn the burner control to "OFF ". Remove one spit at a time by using the ON/OFF switch to bring each spit to the point it can be removed. The spits and birds are very hot heat resistant gloves are required. First, undo the thumb screw and then pull the birds and the skewers into a container. After the birds are removed, the skewers can then be collected and washed ready for reuse.
11. Make sure that the work area used for handling cooked chickens is separate from the area where uncooked chickens are prepared (refer to Health Department Regulations).
12. Chickens need to be maintained at 60°C for sale as cooked chicken. The batch will need to be discarded if allowed to cool below this temperature and not chilled.

Cleaning

Semak Rotisseries cleaned on a regular basis will remain sparkling clean.

Semak recommend that the rotisserie should be cleaned after every cook as part of a HACCP Based Food Safety Program.

To clean the machine:

1. Remove all of the chickens from the machine
2. Remove the spits, skewers and Drip tray and wash in hot soapy water. Rinse
3. Wipe the inside surfaces of the rotisserie with hot soapy water and wipe dry. **DO NOT** wash burner tiles. **Spray** all cooking surfaces with HACCP approved sanitizer and wipe dry.
4. **Never** hose out the machine.
5. Remove the spit sleeve assemblies and soak in a water diluted solution of the oven cleaner. Rinse in hot water and oil the spring with food grade machine oil. **Do Not** use vegetable oil as it will bake on and cause the spring to become sticky rather than free.
6. Remove, empty and wash bucket with hot soapy water. Dispose of contents in an environmentally responsible way.
7. Wipe machine with a HACCP approved sanitizer when finished
8. Wipe the outside of the machine with a damp cloth.

Spit Sleeve Inserts

The spring loaded spit sleeve assemblies, which are located in the drum on the left hand side of the machine, should be removed and cleaned **daily** to ensure longer life and trouble free operation. These assemblies ensure that the spit is positively engaged in the drive dogs of the unit and if not cleaned regularly, gum up with vaporised chicken fat. Prise the assembly out gently using a screw driver or like tool. This overcomes the resistance of the retaining spring and the assembly should then easily slide out of the disc. Clean as detailed above in *step 9*.

Failure to properly maintain the spit sleeve assemblies will subsequently void the manufacturer's warranty on the part.

Glass Care

1. Handle glass with the greatest of care
2. When cleaning do not use hose.
3. **DO NOT** place glass in cold water
4. In the unlikely event of glass breakage, dispose of all birds in the rotisserie and do not use until the glass has been replaced.

Points to Remember

- Never wash glass doors while they are still hot.
- Switch off all controls and isolate electricity when not in use and prior to cleaning.
- Do not operate within 3 metres of flammable material.
- Remove, clean and oil the spit sleeve assemblies daily. When applying lubrication, ensure that only appropriate food grade lubricant is applied. Please contact your distributor or Semak for details of suppliers in your area.

Service and Repair

In the event of breakdown attempt to solve the problem by working through the troubleshooting and FAQ sections of the Instruction manual.

If the problem cannot be identified or fixed contact Semak for technical assistance on 03 9796 4583.

If the problem cannot be solved over the phone a work order or job number will be provided for a technician to attend the machine on site and will require a purchase order or credit card before the booking will be made.

In store service may be subject to call-out, travel time, fuel surcharge, and penalty after-hours rates depending on the problem. Whenever possible Semak will attempt to minimise these costs.

Semak use Authorised Service Agents. No claims will be recognised by Semak if an unauthorised repairer attends the machine.

Warranty claims are subject to Semak's discretion, and all warranty work is to be undertaken by Semak authorised service agents. No claims for warranty will be recognised unless accompanied by a Semak work order number. It is against company policy to provide verbal confirmation or authorization for warranty repair over the phone.

Service and Repair Procedure

1. Attempt to identify the problem
2. Contact Semak phone: 03 9796 4583
3. Obtain a work order number
4. Provide a purchase order number or credit card number
5. Details we will require at the time you call
 - Date of purchase
 - Serial Number
 - Certificate of Compliance Number
 - A completed *Repair Request* Form (see page 20)
 - Quote required?
6. An indication of urgency to avoid unnecessary attendance costs.
7. Ask for a Semak Work Order Number. This may be faxed to you on request.
8. Payment for repairs will not be made without a work order number.

Warranty

THIS WARRANTY APPLIES ONLY TO PRODUCTS MANUFACTURED AND SOLD IN AUSTRALIA

The benefits conferred by this warranty are an alternative to all other rights and remedies in respect of the product which the consumer has under the Trade Practices Act and similar State and Territory Laws.

Semak warrant each new appliance to be free from defects in materials or manufacturing process for a period of 1 year from the date of original purchase.

Should defects due to faulty materials or manufacturing process develop within the warranty period, the appliance will be repaired without charge providing all conditions of this warranty are observed.

1. Proof of Purchase must be retained by the purchaser.
2. This Warranty is void if the equipment has been damaged due to misuses neglect or is used for a purpose for which it was not suited; and no repairs, alterations or modifications have been attempted by other than Semak or its authorised Service Agent.
3. Semak is not responsible for service required due to misapplication, improper installation, inadequate wiring, incorrect voltage conditions, nor for consequential damages of any kind. Where required by Statute or local authority, equipment must be installed by qualified person in accordance with all relevant regulations.
4. Cost of transport of any appliance or part to and from Semak or its Service Agent is to be paid by the owner.
5. A charge will be made where failure is due to neglect, abuse or accidental damage on the part of the operator, or when no fault can be found or the fault is due to causes outside the control of Semak.
6. The above does not preclude the purchaser from their Statutory rights as a consumer.

Register Warranty Online at

www.semak.com.au

FAQ—Troubleshooting

1. Gas Related Problems

- eg. Pilot won't light
- Pilot keeps going out
- Burner is going out mid-cook
- Burner won't light

Phone Semak to determine the problem on 03 9796 4583. Complete and fax the Repair request in this manual and fax to Semak on 03 9796 4586 with a copy of Certificate of Compliance for the installation of the machine.

Once all of the information is received a gas fitter may be required to attend the machine. It is the responsibility of the gas fitter to ensure that the machine is installed or operating correctly after repair.

2. Electrical Problems

- eg. Motor won't work
- Control Panel is not working
- Indicator lights are not working

Phone Semak to determine the problem on 03 9796 4583. Complete and fax the Repair request in this manual and fax to Semak on 03 9796 4586 with a copy of Certificate of Compliance for the installation of the machine.

Once all of the information is received an electrician may be required to attend the machine. It is the responsibility of the electrician to ensure that the machine is installed or operating correctly after repair.

3. Mechanical Problems

- eg. Motor is noisy
- Spits are not rotating or rotating incorrectly
- Gears are noisy

Phone Semak to determine the problem on 03 9796 4583. Complete and fax the Repair request in this manual and fax to Semak on 03 9796 4586. Where the machine is out of warranty Semak will advise of the closest repairer.

If under warranty a work order number will be provided on request and a service agent will be booked to attend the machine at your convenience.

Repair Request Form

Office Use:	
Work Order No:
Priority
Service Agent:
Contact Number:
Contact Person

Your Details:

Company Name:

Company Address

.....

Contact Person

Phone Fax Email

Equipment Details:

Product: Rotisserie Model: Serial Number:

Description of Problem:

.....

.....

Description of how the product is being used:

.....

.....

Describe what happened just prior to the machine breaking down:

.....

.....

Description of how the product is being cleaned:

.....

Level of Urgency:

Priority 1	Require immediate breakdown assistance	same day attendance	<input type="checkbox"/>
Priority 2	Machine is working	1-3 days	<input type="checkbox"/>
Priority 3	Service required	4-7 days	<input type="checkbox"/>

Hand Over Checklist

[Store Copy](#)

The following Competency Checklist must be completed to ensure the safe and correct operation of your Semak Rotisserie.

Supplied To		Supply Date	Hand-Over Date
Address			
City	State	Post Code	Phone Number
Product Name		Model Number	Serial Number

This is to certify that the undersigned person is authorised to accept this equipment on behalf of the above company and has been trained to safely operate the equipment and apply the essential operating, hygiene and maintenance procedures as follows:

- Trained in:
- Safety features and warning devices of the equipment
 - Hygiene (cleaning and sanitation procedure)
 - Operation procedures Load, Selecting/Programs, unload, manual override
 - Safety Risks associated with the machine
 - Emergency Procedures
 - Maintenance and Repair

Authorised Employee(s)	Signed	Date

At the time of handover the equipment was fully operational and showed no signs of defects

Semak Agent	Signed	Date

The following Competency Checklist must be completed to ensure the safe and correct operation of your Semak Rotisserie.

Supplied To		Supply Date	Hand-Over Date
Address			
City	State	Post Code	Phone Number
Product Name		Model Number	Serial Number

This is to certify that the undersigned person is authorised to accept this equipment on behalf of the above company and has been trained to safely operate the equipment and apply the essential operating, hygiene and maintenance procedures as follows:

- Trained in: Safety features and warning devices of the equipment
- Hygiene (cleaning and sanitation procedure)
- Operation procedures Load, Selecting/Programs, unload, manual override
- Safety Risks associated with the machine
- Emergency Procedures
- Maintenance and Repair

Authorised Employee(s)	Signed	Date

At the time of handover the equipment was fully operational and showed no signs of defects

Semak Agent	Signed	Date

Hand Over Checklist

Semak Copy

The following Competency Checklist must be completed to ensure the safe and correct operation of your Semak Rotisserie.

Supplied To		Supply Date	Hand-Over Date
Address			
City	State	Post Code	Phone Number
Product Name		Model Number	Serial Number
<p>This is to certify that the undersigned person is authorised to accept this equipment on behalf of the above company and has been trained to safely operate the equipment and apply the essential operating, hygiene and maintenance procedures as follows:</p> <p>Trained in:</p> <ul style="list-style-type: none"> Safety features and warning devices of the equipment <input type="checkbox"/> Hygiene (cleaning and sanitation procedure) <input type="checkbox"/> Operation procedures Load, Selecting/Programs, unload, manual override <input type="checkbox"/> Safety Risks associated with the machine <input type="checkbox"/> Emergency Procedures <input type="checkbox"/> Maintenance and Repair <input type="checkbox"/> 			
Authorised Employee(s)		Signed	Date
At the time of handover the equipment was fully operational and showed no signs of defects			
Semak Agent		Signed	Date

Warranty Registration

Retain for Future Reference

DO NOT SEND

Please complete one registration for each Semak appliance.

You may be required to provide this information when requesting after sales service. Please staple your proof of purchase to this page.

Company Name: _____

Company Address: _____

Business Type: _____

Contact: _____

Phone: _____

Fax: _____

Email: _____

Product: _____

Serial Number: _____

Date of Purchase: _____

Place of Purchase: _____

